

4. FINISH TO BUILDER'S TASTE.  
NO FINISH REQ'D.

3. RADII:

3.1 FILE WORKING RADII TO SUIT.  
POLISH WITH 600 GRIT EMERY.

3.2 RADII ON OUTER LEAFS BIASED TOWARD  
CENTER LEAF, AS SHOWN IN DETAIL 1.

3.3 RADIUS ON CENTER LEAF IS SYMMETRICAL.  
RADIUS IS 1/2 MATERIAL THICKNESS.

2. SUGGESTED RAW STOCK:

1/8" X 1 1/2" STEEL FLAT BAR

1. DIMENSIONS NOT SHOWN ARE TO  
BUILDER'S TASTE.

NOTES: (UNLESS OTHERWISE SPECIFIED)

ENGINEERING RESPONSIBILITY



SEPIA



11									
----	--	--	--	--	--	--	--	--	--

FLUTING PLIERS

SYM	REVISIONS	APPROVED	DATE
	REFER TO SHT 1		

R 3/32  
(APPROX.)

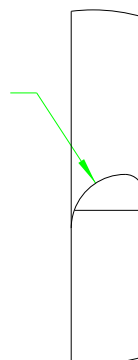

Detail1  
SCALE 3X

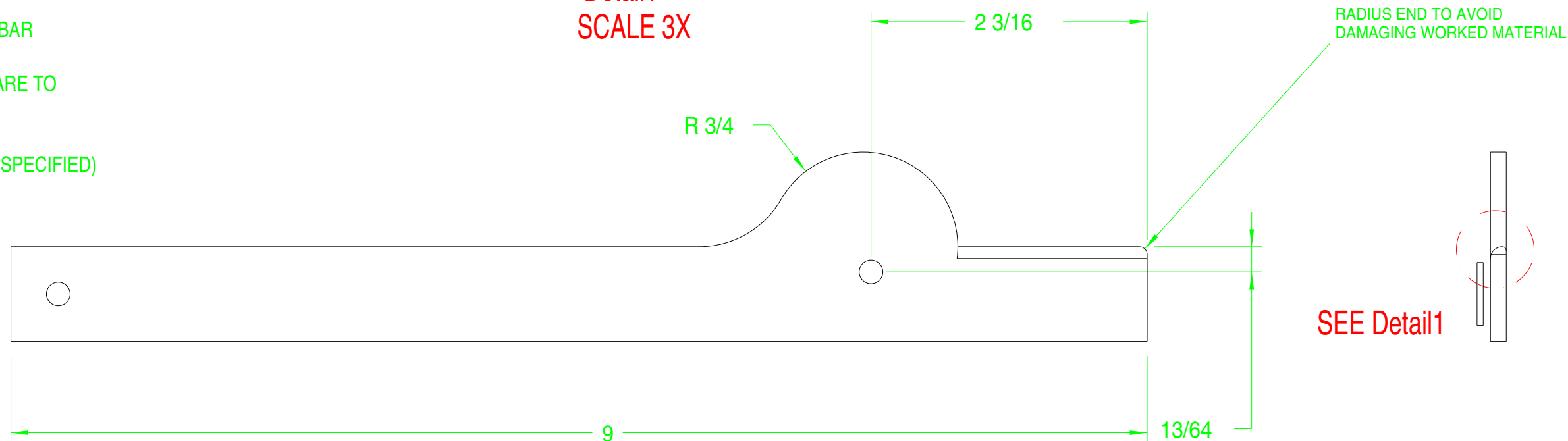

DO NOT SCALE THIS  
DRAWING

<p>UNLESS OTHERWISE SPECIFIED</p> <ul style="list-style-type: none"> <li>DIMENSIONS ARE IN MILLIMETRES</li> <li>THIRD ANGLE PROJECTION</li> <li>TOLERANCES</li> </ul> <p>STRIKE OUT OR FILL IN AS NEEDED</p>	1	A/R	PART/MATERIAL DESCRIPTION					
	ITEM	QTY.	PART/MATERIAL-DESCRIPTION			MAT'L-PART NO.	MAT'L-DWG NO.	MAT'L-SPEC.
	T. MCHENRY DRAWN BY		00/04/17 DATE	FLUTING PLIERS LEAF DETAIL			Van's Air Force Western Canada Wing	
	ENGINEER/CHECKER			TITLE			NIL PART NUMBER	
RELEASE TO PROD.			FULL SCALE			2 SHEET	2 OF	FLUTING PLIERS
FILE REVISED BY								